

workshop 2006



www.magura.com



the passion people

Deutsch

English

Nederlands

Français

Italiano

Espanol

Summary

| | |
|--|-------|
| 1. Introduction | 3 |
| 2. Safety instructions before the first ride | 4 |
| 3. Safety instructions before every ride | 4-5 |
| 4. Transport of the bicycle | 5 |
| 5. Warranty | 5 |
| 6. Brake installation | 6-9 |
| 7. Installation FIRM-tech® | 10 |
| 8. Shortening and routing the hose | 11 |
| 9. maintenance/ brake pad change | 13 |
| 10. Filling and bleeding | 14 |
| 11. Repairs | 15 |
| 12. Brake pads | 16 |
| 13. Accessories | 17 |
| 14. Spare parts exploded view | 18-19 |



WARNING:

This symbol means possible danger for your health and even life if you do not follow the instructions given respectively if the necessary safety measures are not followed.



ATTENTION:

This symbol warns you of inappropriate handling that might cause serious damage to the material and/ or the environment.



NOTE:

This symbol gives you additional information about the general handling of the product or gives hints to paragraphs in this manual which have to be read carefully.



For your own safety you should not overestimate your technical skills! We advise you to leave the following works in case of any doubts to a professional bike mechanic.

1. Welcome to the Passion People!



Brake lever (master cylinder)
MAGURA HS 33

Congratulations! You have purchased a fully hydraulic MAGURA rim brake proudly „Made in Germany“. You will be amazed at the awesome braking power and the minimum amount of maintenance that is necessary on our stoppers. Good to know that you are not alone, millions of riders worldwide rely on them and every day our numbers are increasing



Brake calliper (slave cylinders)
MAGURA HS 33

On the fully hydraulic MAGURA rim brake systems HS 33 and HS 11 the braking force is transmitted to the braking surface by a mineral oil column. The movement of the lever blade moves a piston, which is integrated in the brake lever (master cylinder). The piston pushes the mineral oil column through the brake hose in the direction of the brake calliper (slave cylinders), where two pistons, on which the brake pads are clipped, are pushed out. The friction between the brake pads and the rim slows down the bicycle and causes a heating of the rim.

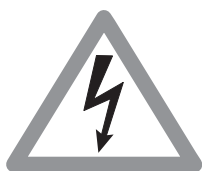

Never touch the rim after long braking as this may cause serious burns!

You will be pleased to find out that the MAGURA rim brakes offer a superior braking power even with little hand force applied, no matter what the weather conditions should be. Please note, however, that rim brakes are generally not as powerful in the wet in in snowy conditions mainly and that the reaction of the brake will be slightly retarded under these circumstances.

Our rim brakes cause a wear of your rims. So do not forget to check regularly your rims!

This manual contains important information about the safe installation, operation and maintenance of your MAGURA rim brakes. We urge you to read it carefully, become familiar with its contents and follow our recommendations to help make your new braking experience enjoyable and trouble free.

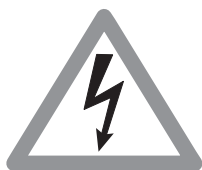

All setup steps will be explained on the HS 33 rim brake. Any differences with the HS 11 model will be clearly mentioned.

Although the MAGURA rim brake systems are relatively simple you should not overestimate your technical skills! We therefore advise you to leave the following works to a trained technician of a professional bike shop.

In case of any further questions or problems we warmly recommend to visit our website www.magura.com where you will always find the newest and hottest tips about all our products. On magura.com you can also download this manual in a more convenient A4 format. Stay tuned with the Passion People!

Thank you for your confidence in our products, enjoy your ride and your new MAGURA stoppers!

Happy trails!

2. Before the first ride

1. Are you already familiar with hydraulic rim brakes? Our brakes might be much more powerful than the stoppers on which you relied so far. Take your bicycle to a safe area to learn the proper braking technique and operation of your new brakes and your bike.

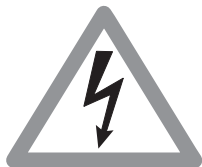

2. Check that the front brake is still actuated by the lever on the side you are used to braking with. Should this not be the case you will have to train to your new setup otherwise any unintended front wheel braking manoeuvre may cause an accident leading to possible serious injury! If in doubt get a trained technician to swap the hoses. For further hints concerning the swapping of the brake hose see page 11 onwards.

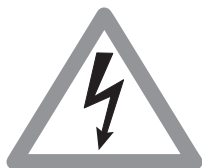

3. While riding in extreme conditions (total weight of bike plus rider over 100 kg and/ or a gradient of more than 15 %) always use both brakes simultaneously to slow your bike down.

4. Do not use a MAGURA rim brake for downhill sport! Any misuse might cause serious accidents with fatal injuries both to yourself and others!

5. Are you familiar with the other components on your bike such as gears, clipless pedals and suspension units? Always practise using your bike in a safe area to improve your handling abilities before using it on road. Consult the user's manual of your bike to learn more about this.

6. For your own safety always wear a helmet when you ride a bicycle. Make sure as well that you wear suitable clothing and footwear.

3. Before every ride

always check carefully the following points:

1. Always make sure that the quick release skewers of your wheels and seat post are correctly mounted and closed.

incorrectly installed quick release skewers might cause the fixed items to become loose. Serious accidents with severe injury may result!!

2. Always make sure that the brake lever pressure is o.k. by pulling the lever blade and ensuring that full braking performance is achieved before the lever blade touches the handlebars.

In case, of changing pressure points during a ride you might have air in the brake system. See hints about filling and bleeding from on pages 14-16.

3. Always make sure that the brake system does not have any leaks by activating the lever blade, holding it and checking the hose connections and brake lever for eventual leaks. (Also see page 11)

4. Always protect your rims and brake pads from oil and lubricants (e.g. by lubricating your chain).

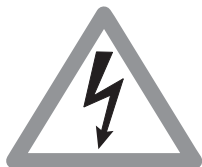

Contaminating the pads with oil and lubricants will cause a permanent loss of braking power. Clean contaminated rims and pads with isopropyl alcohol or with warm dishwater.

See further hints about the brake pad change on page 13.

5. Release your brake lever and check whether your wheel moves freely and without drag. Check eventually whether the wheels are correctly mounted and if the quick release skewers are tightened sufficiently.

6. Are your tires in a good condition, and have they enough air pressure? Test this with your fingers. Lift up your bike and turn the wheels of your bike. An insufficient rotation might be due to damaged tires, broken axles and/or broken spokes.

7. Pick up your bike and let it drop from a moderate height. Listen for any rattling noises. If any are heard check the bearings and all screwed connections.

8. Always follow the instructions given in the owner's manual of your bicycle.

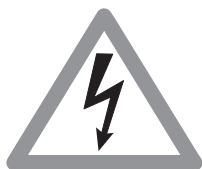

Never use your bicycle if any of the points mentioned above relate to your bicycle. Consult a professional bike mechanic if you feel unsure. A faulty bicycle may result in serious accidents with possible fatal injuries of the rider!

4. Transport of the bicycle

For a transport in an aircraft you can leave your brake as it is, e.g. you do not have to empty it.

Beside of this there are no further activities necessary. Always make sure that the hose is not snapped or damaged during transport!

5. Warranty



MAGURA is giving a **5-year leakproof warranty** on brake levers (master cylinder) and brake callipers **if you register your brake online on magura.com**. Watch out for the red info sheet in the middle of this manual!

This warranty is void when damage to the brake has occurred from the following:

- abuse
- mixing and matching the brake with parts from other manufacturers
- damage of the exterior finish caused by improper use
- any attempt to disassemble the whole brake
- modifications
- non-factory changes or improper service

We expressly point out that a warranty claim is only accepted with a clear proof of purchase (payment receipt of the dealer!) and online registration on magura.com!

6. Brake Mounting

1. Tools for mounting (+maintenance)

Allen key 2*, (3), and 5 mm
8 mm open end wrench
sharp knife

(* delivered with the brake)



Please insert the allen key completely to avoid damaging the bolts.

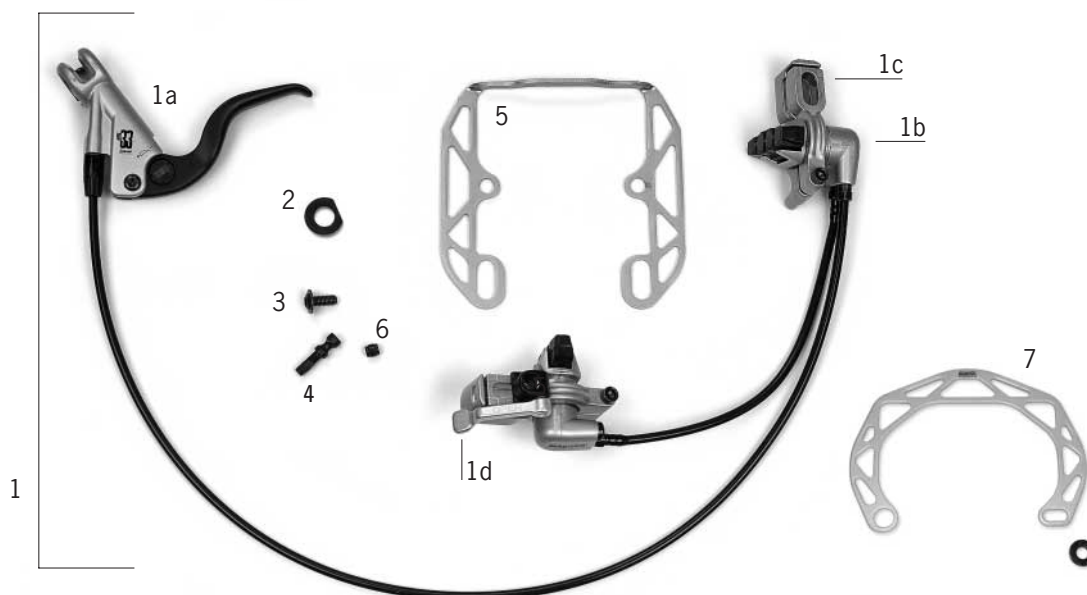

Unpack your MAGURA brake and arrange all parts (The quantities mentioned here refer to after-market sales boxes including a complete brake set)

1. Preassembled brake, filled and bled, ready for mounting (2 pieces)
1a brake lever (or master cylinder)
1b brake cylinder (or slave cylinder)
1c EVO2 adaptor
1d quick release
2. cantistud U-washers (4 pieces)
3. fitting bolt for EVO2 adaptor (2 pieces)
4. quick release (or hourglass) bolt (2 pieces)
5. EVO2 mounting plate (2 pieces)
6. olives (2 pieces)
7. EVO 2 booster and washer (2x)

Contents in the sales box may vary, mainly in the US!



1. Mount the brake lever onto the handlebar. **(Tightening torque 4 Nm/ 34 in.lbs.**
Hint: Tighten the brake lever so that you can still turn it by hand on the handlebar when you apply big forces. This old motocross trick will reduce crash damages.



2. Screw in the quick release bolt into the left (frontwheel) resp. right (rearwheel) canti stud (seen in rotation direction).



3. Mount a canti stud washer on both canti studs, flat side pointing up. Tip: to prevent losing the washers, use silicon glue to semi-permanently fix them on the studs.



4. Use only ONE washer per stud!



5. Slide the EVO2 mounting plate on the canti studs.



6. EVO2 label has to be legible from assembly position and must not stand upside down! **In the following pictures the wheel is often is often not in place, this is purely to help show the details better. Mounting a MAGURA brake with the wheels in place is much simpler, for this reason, if at all possible, do not remove the wheels.**



7. The upper cones of the adaptor must fit properly into the drill of the EVO2 mounting plate. Mount the left side with an Allen key no. 5 **(6 Nm/ 51 in.lbs)**. Do not tighten fully yet the bolts.



8. Before you install the right side check out how easy it is to change MAGURA brake pads. Simply click them in! Slide the right side onto the canti stud and close the quick release.

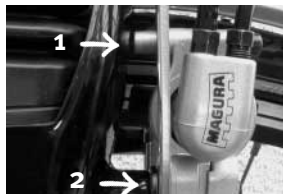

9. Side view of a correctly installed EVO2 unit. There is a sufficient clearance between upper cone of the adaptor and fork booster (arrow 1). The washer is installed between canti stud and EVO2 mounting plate (arrow 2).



10. Push the slave cylinders towards the rim while adjusting them properly, i.e. PARALLEL to the rim.



Care for a correct adjustment of the brake pads that have to be parallel to the rim!



11. Pull slightly the lever blade to push back the slave cylinders and tighten the bolts when you have a gap of 2 mm between rim flange and brake pads.

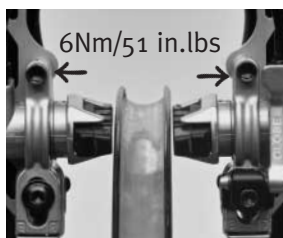

12. A perfectly aligned MAGURA brake:

- brake pads **parallel** to the rim, distance pad/ rim 2 mm on both sides.
- Connection hose between the brake cylinders points inboard, i.e. frame/fork.
- Quick release points up when it is closed.

Respect at any rate the indicated tightening torques!

6Nm/
51 in.lbs 4,5Nm/
39 in.lbs



13. Check the quick release tension when it is closed. Increase it, if necessary, by turning in the quick release bolt clockwise (**4,5 Nm/ 39 in.lbs**).



14. EVO 2 booster installation.
The side with the wide drill is mounted on the quick release side of the adaptor. Do not forget the washer under the head of the fitting bolt. **Max. tightening torque is 6Nm/51in.lbs.** On the opposite side the round drill of the EVO 2 booster just slips over the mounted bolt.



15. Reach adjust (only available with HS 33) is done with a 2 mm Allen key. Turning key clockwise: lever moves to the handlebar, turning counterclockwise: lever moves away from the handlebar.



16. Brake pad wear adjustment HS 33
Turn the red Turbo Pad Adjuster (TPA) in “-” direction. Pads move towards the rim.



17. Brake pad wear adjustment HS 11
Turn 4 mm Allen screw clockwise: pads move towards the rim.

7. Installation of FIRM-tech® models

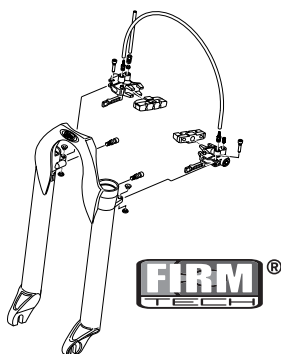

If you are the proud owner of a MAGURA suspension fork with FIRM-tech equipment, mounting the brakes is a breeze. Fit the fork and mount the brake lever to the handlebar as described. Fit the slave cylinders of the brake as shown on page 18 of this manual.



1. Check out the double quick release comfort! To **open** it push the quick release in direction of the wheel; you can now move the brake cylinder to change your wheel or the brake pads. Quick release tension is adjusted similar to standard version (c.f. page 8)



2. Close the quick release: Push the brake cylinder back towards the fork. Close the quick release by doing the same. That's all!

A booster is not necessary with FIRM-tech and not foreseen either. It is not possible to mount one!



3. Adjust the brake pads to the rim width with the 5 mm allen screw which is integrated in the brake cylinder. By turning the screw clockwise the pad approaches to the rim.



4. With FIRM-tech you adjust the brake pad to the rim on both sides with the 5 mm allen screw.

Shorten the hose and pad wear adjustment as described in the respective chapters!

8. Shorten and route the hose



1. **HS 33.** Turn the red Turbo Pad Adjuster (TPA) **fully** back in “-” - direction and unscrew, if necessary, the 2mm reach adjust screw as well.



2. **HS 11.** Turn the 4 mm allen bolt **fully** counterclockwise.



3. If your frame is not equipped for routing hydraulic lines you can find in our accessory program the hose clips....



4.and hose guides.



5. Unscrew the 8 mm sleeve nut at the slave cylinder.



6. Pull out the hose **carefully**.
Never activate the lever blade with the system open! Hold the tubing carefully in order to avoid any loss of oil!



7. Put the hose on a hard surface. Cut the hose squarely just behind the olive using a cutter, never use pliers or a saw.

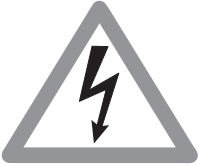

8. **The olive must be replaced! Hold the hose carefully so that it cannot spring away! Cut squarely and on a hard surface to achieve a clean cut. Never use pliers or a saw!** Throw away the hose piece with the fitted olive. Slide off the sleeve nut. Slide the hose **carefully** through the heatshrink tube. Measure the correct length of the hose (don't forget to turn the handlebars!) and cut the tubing as described.



9. The black olive cannot be mounted incorrectly, as it is symmetrical. Push the hose **all the way** into the slave cylinder.



10. Do not crosstread! After initial start by hand use an 8 mm open end wrench. **(Tightening torque 4 Nm/ 34 in.lbs).**



11. **Always check for correct installation by pulling on the hose Make sure that the system has no leaks by activating the levers and checking all connections.**

9. Maintenance/ brake pad change



1. brake pad wear adjustment HS 33

Turn the red Turbo Pad Adjuster (TPA) in “+” direction. Pads move towards the rim.

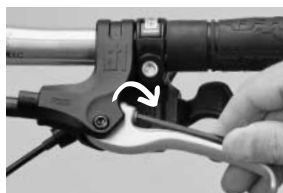

2. brake pad wear adjustment HS 11

Turn 4mm Allen screw clockwise: pads move towards the rim.

MAGURA brakes do not need any special maintenance after correct installation. Regular bleeding is absolutely not necessary, because the MAGURA Blood mineral oil does not contract water like DOT brake liquid used in cars, on motorcycles and competitors' products.

Brake pad wear adjustment as shown above.

When

- the red TPA (HS 33 models) is turned all the way in
 - the 4 mm allen bolt is in flush with the lever blade (HS 11)
- it is time to change the pads.



Before changing the pads you must always screw back the adjusting screws to their start position!

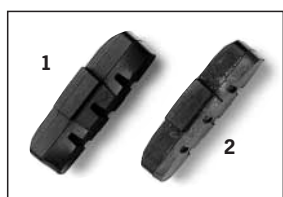

3. New (1) and worn (2) brake pad. When your brake pads are worn as shown it is time to change them.



4. To change the brake pads, open the quick release, remove the brake from the canti stud, pull out the old pad and then just snap in a new one. After removing the wheel, pull out the old pad and snap in a new one on the other side. That's all!



10. Filling and bleeding



The filling and bleeding of a MAGURA brake is not a routine work. This is due to the fact that the MAGURA Royal Blood hydraulic oil does not absorb water like DOT brake liquid in cars and on motorcycles. A filling and bleeding of a MAGURA is therefore only necessary in case of an incorrect installation or a tubing change after a crash. Only use MAGURA Royal Blood hydraulic oil, never DOT brake liquid!



1. The service kit contains everything you need which you need for bleeding or repairing your MAGURA brake.



Push (by hand) a barbed fitting into **both** the transparent filler and vent tubes.



2. Put the filler tube on the syringe and fill **completely** with MAGURA ROYAL BLOOD mineral oil. In the case of an emergency, cooking oil will work, but needs to be flushed out after the return to civilization. **Never use DOT brake liquid! Pay close attention not to have any air in the tube or syringe.** Remove bleed screw (5mm allen screw) at the slave cylinder. Fit filled syringe and filler tube and **fix it** with an 8mm open end wrench.

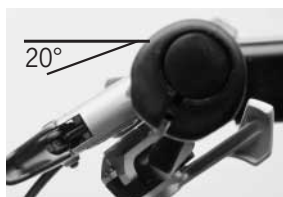

3. **HS 33:** Turn the brake lever (HS 33) on the handlebar from the horizontal position until it is in the shown 20° angle. Turn back **fully** the TPA knob in the “-” position.
HS 11: Turn the brake lever on the handlebar horizontal. Turn fully back the 4 mm pad adjustment screw.

Remove the bleed screw in the brake lever.



4. Install the vent tube and hold its end into the oil bottle.



5. Push the oil through the system. **Use the whole content of the syringe.** You can see air in the form of small bubbles in the vent tube.



6. The bleeding procedure is completed when no more air bubbles can be seen in the vent tube. Remove the vent tube and replace the bleed screw. **(Tightening torque 4 Nm/ 34 in.lbs).** Remove syringe from slave cylinder and replace the bleed screw. **(Tightening torque 4 Nm/ 34 in.lbs).** Return brake lever to its normal riding position, and clamp correctly. **(Tightening torque 4 Nm/ 34 in.lbs).**

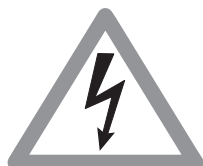

They system is correctly bled when the pads move immediately upon activating the lever-blade. Adjust the pad/rim clearance with the TPA or the allen adjustment bolts (see chapter maintenance/pad change). Check the entire system for oil leaks. Check the flawless performance, high power and excellent modulation.

11. Repairs



1. Repair of a HS 11 main hose with barbed adaptor connection.



2. To do this clamp the hose as shown with the help of the two clamping jaws into a vice. 1,5 cm of the hose have to stick out of the clamp. Use a nylon mallet to tap the barbed fitting into the tubing. **The barbed fitting must be installed as shown. Never use a lighter or a heatgun to soften the hose.**



3. Screw the repaired hose into the prepared thread.



4. Correctly installed repaired hose on an HS 11. The barbed fitting is **flush** with the brake lever (arrow). The brake now has to be re-filled as described in the chapter 'filling and bleeding'.



Further repair tips

In case of a damaged brake-cylinder crossover-hose, proceed as described above from points 1 to 4.

Spare brake levers and slave cylinders are delivered „dry“. If you have to replace a brake lever or slave cylinder, the MAGURA system has to be bled **twice** after changing the defective item. Activate the lever blade after the first bleed to chase all air bubbles and to make sure that the oil is well distributed in the new part.

Leaking brake levers and slave cylinders have to be replaced as complete units. Due to product liability reasons MAGURA neither offers spare pistons nor internal seal repair kits.

12. brake pads



MAGURA offers four different brake pad compounds for different riding styles and rim surfaces.



black (0321 406)

standard brake pad for polished rim surfaces. **Series pad on all brake models.**

red (0720 423)

race oriented brake pad for polished rim surfaces. **Excellent for trials!**



grey (0321 407)

standard brake pad for hard anodized (black) and ceramic coated rims.

green (0720 439)

race-oriented brake pad for hard anodized (black) and ceramic coated rims.



ATTENTION: Do not forget that the brake pads are subject to an increased wear if you use ceramic coated rims, so check them regularly!

All brake pads are sold as a complete set of 4 pieces.

13. accessories



1. Stainless steel hosekit.

Cool looks and totally bomb-proof. Available as kit for a complete brake-set **(0720 846)** and as single hose in a 1700 mm length **(0721 203)**.



2. Hose guides (0721 214)

for all those who care for a clean and esthetic hose routing along the toptube. Installation is a snap. The guides are just screwed into the cablestops. The hydraulic hose is simply clipped in. **2 pieces.**



3. MAGURA 90° hose fitting kit (0321 285)

makes the necessary 90° hose connection possible onto brake levers for recumbents, HPV's or on time trial bars. **Only compatible with HS 33; 2 pieces.**



4. HS 11 alloy lever blades. On a lot of bikes which come with MAGURAs as OE equipment you often find „simple“ composite lever blades. The Passion People offer a large range of tuning lever blades in quality aluminium, for example the lever blades for the HS 11. **Available in silver (0721087)**. All lever blades are sold in a set of 2 pieces.

14. spare parts 2006/ max. tightening torques

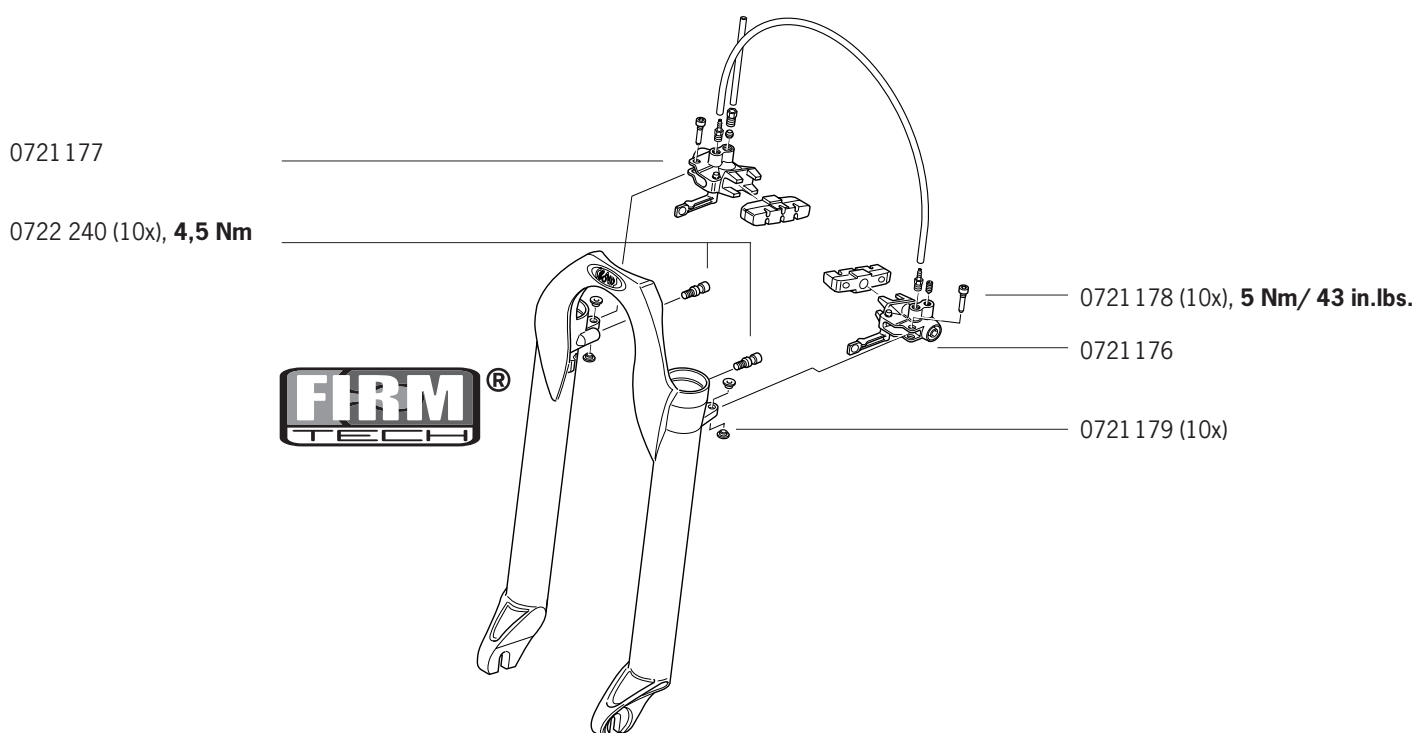
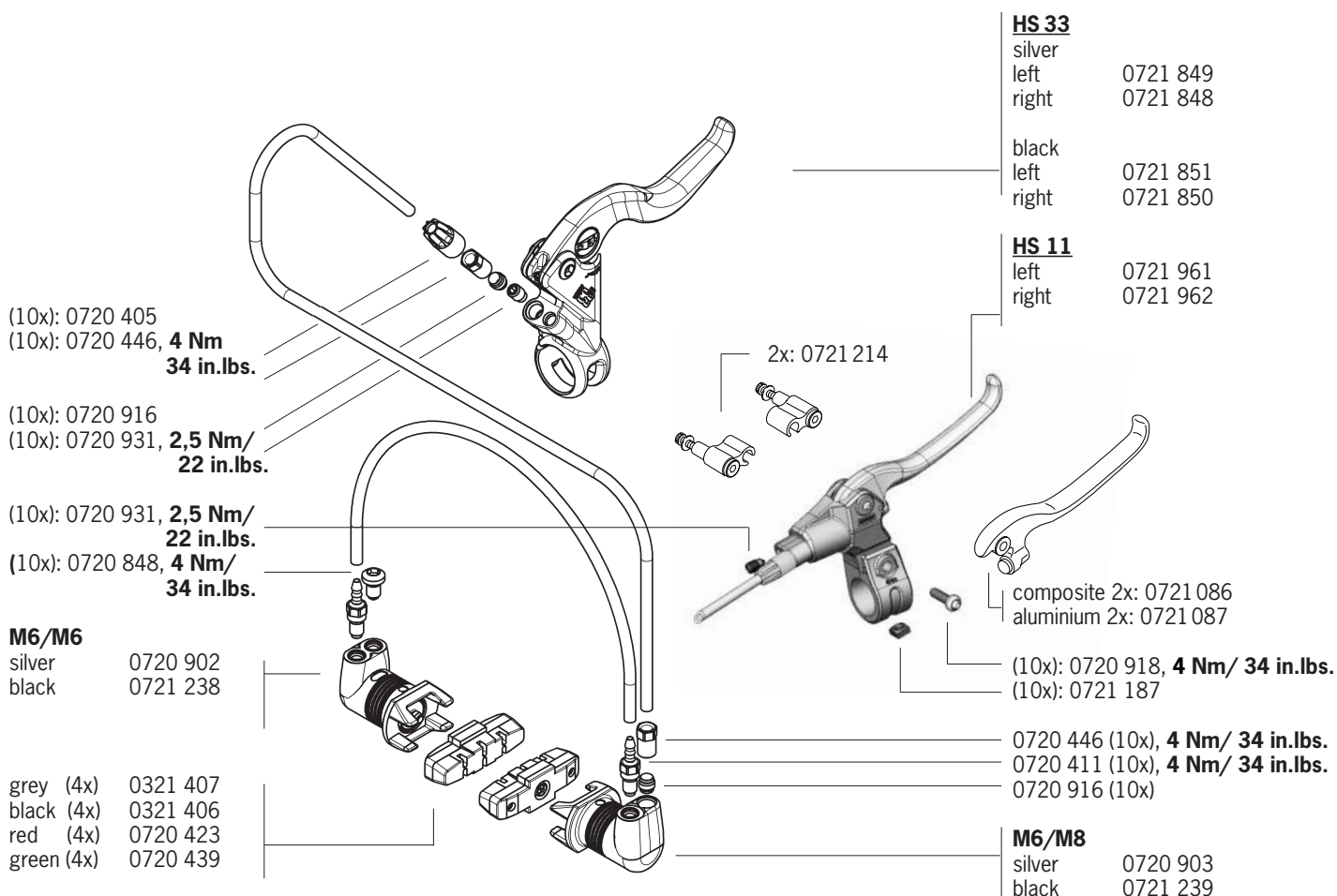

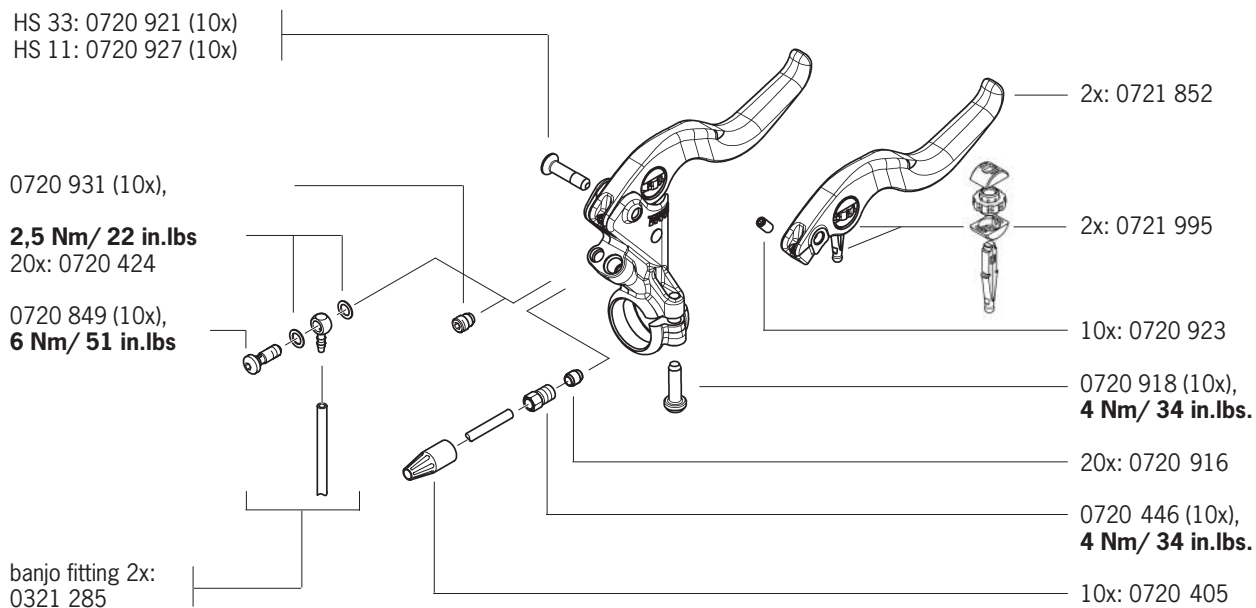

EVO2

EVO2 adaptor complete:
silver 0721 853

silver 0721 908
black 0721 907

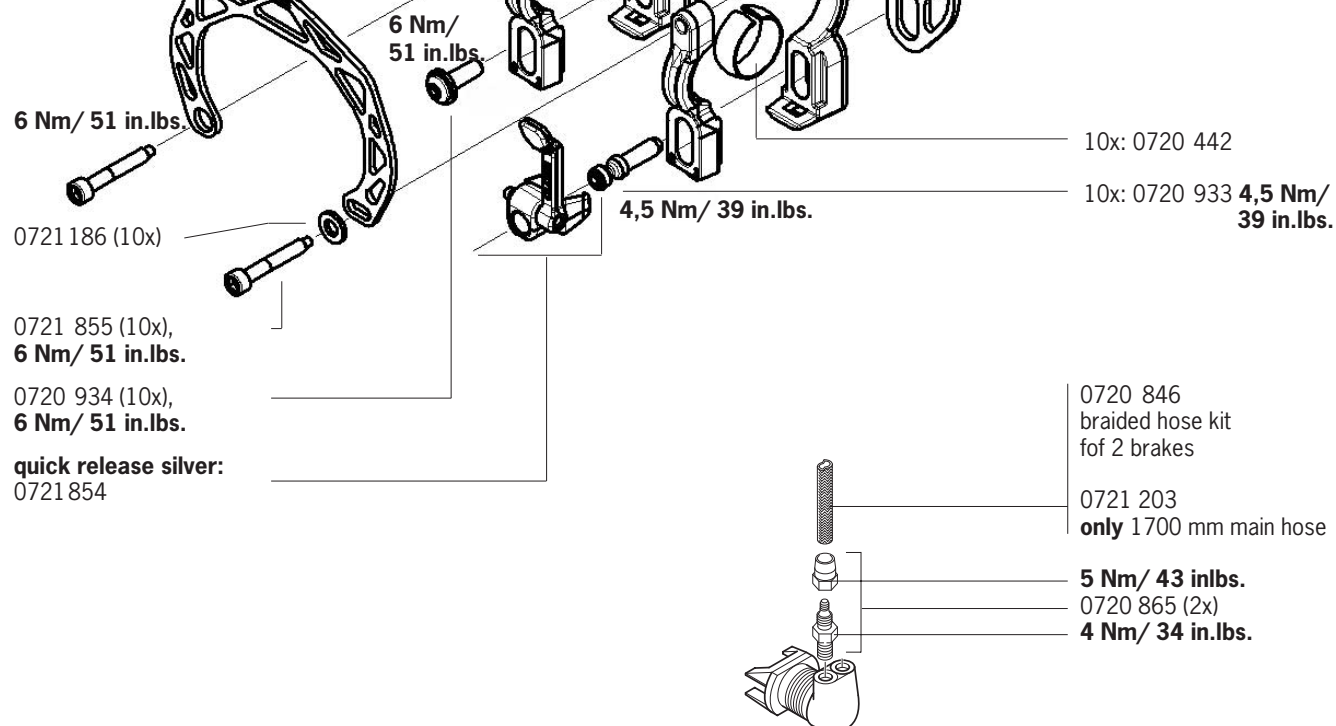

MAGURA Bike Parts
GmbH & Co. KG

Heinrich Kahn Straße 24
D-89150 Laichingen
info@magura-bikeparts.de

www.magura.com

Hotline | Helpdesk:
phone 0190-648124
41 ct. pro Minute aus dem
deutschen Festnetz
werktätlich von 9 bis 15 h
fax 07333-962651
service@magura.de

**MAGURA
Partners and Service
Centers Worldwide**

Andorra

Esports Jorma
phone 376-844133
fax 376-843022
jorma@correu.andornet.ad

Australia

TMO Sports
phone 02-9695-7744
fax 02-9695-7844
service@velovita.com.au

Austria

MAGURA Service
Center Austria
phone 0662-643703
fax 0662-643802
service_austria@magura.de

Belgium

Transmission
phone 010-244646
fax 010-244777
info@transmission.be

Canada

MAGURA USA
phone 618-3952200
fax 618-3954711
magura@magurausa.com

Czech Republic

Sport 04
phone 0312-698016
fax 0312-698025
info@scottssports.cz

Denmark

Borandia APS
phone 47-107172
fax 47-107066
borandia@borandia.dk

Finland

Best Brakes Ky
phone 050-591 5863
fax 019-388485
info@bestbrakes.inet.fi

France

MAGURA Service
Center France
phone 0825-886295
(indigo)
fax 03 81 88 49 92
sav_france@magura.de

Great Britain

MAGURA Bike Parts UK Ltd.
phone 01530-837195
fax 01530-811286
service_uk@magura.de

Greece

Nikos Maniatopoulos S. A.
phone 2610-993 045
fax 2610-990 424
amarket@idealbikes.gr

Hong Kong

MAGURA ASIA Inc.
phone +886-4-23106839
fax +886-4-23283734
service@magura.com.tw

Hungary

Mali Bicycle Technology
phone 01-4207563
fax 01-4205321
mali@mali.hu

Ireland

Beara Bike Trading
phone 064-89134
fax 064-41334
wschmidt@indigo.ie

Italy

Areab
phone 0438-435550
fax 0438-439847
info@areab.it

Japan

MC International
phone 06-6536-0901
fax 06-6536-0907
mcinter@mx1.alpha-
web.ne.jp

Korea

MAGURA ASIA Inc.
phone +886-4-23106839
fax +886-4-23283734
service@magura.com.tw

Lativa

SIA »ELKOR STILS«
phone +371-7070750
fax +371-7070456
sport@elkor.lv

Luxemburg

Transmission
phone +32-10-244646
fax +32-10-244777
info@transmission.be

Netherlands

NZ Parts
phone 010-2340468
fax 010-2340824
nzparts@tiscali.nl

Norway

Botolfsen
phone 022-630610
fax 022-970662
info@botolfsen.no

Portugal

LPL-Artigos Desportivos
phone 021-4835354
fax 021-4835362
lpl@netcabo.pt

Singapore

MAGURA ASIA Inc.
phone +886-4-23106839
fax +886-4-23283734
service@magura.com.tw

Slovenia

Maraton D.O.O.
phone +386(0)74990870
fax +386(0)74990872
maraton@siol.net

Slowakia

AGF Invest s.r.o.
phone 02-62859549
fax 02-62859052
info@agfinvest.sk

South Africa

Cycles Africa
phone 011-678-1548
fax 011-678-1548
cunning@mweb.co.za

Spain

■ SAT MAGURA: Bicisport
Sólo para reparaciones y
servicio!
phone 93-3404480
fax 93-3404480
■ Bicicletas Monty
phone 93-6667111
fax 93-6667112
monty@monty.es
■ Casa Masferrer
phone 93-8463444
fax 93-8465355
cmcenter@casamasferrer.com
■ Comet
phone 943-331393
fax 943-551407
comet@comet.es
■ Representaciones
Spinola & Perez
phone 619-702946
fax 93-2317731
c.perez@spinolaperez.com

Sweden

Jaguarverken AB
phone 060-669800
fax 060-669809
info@jaguarverken.se

Switzerland

■ Intercycle
phone 041-9266511
fax 041-9266355
info@intercycle.com
■ Amsler & Co.
phone 052-6473636
fax 052-6473637
info@amsler.ch

Taiwan

MAGURA ASIA Inc.
phone +886-4-23106839
fax +886-4-23283734
service@magura.com.tw

USA

MAGURA USA
phone 6183952200
fax 6183954711
magura@magurausa.com
www.magurausa.com

© MAGURA 2005
All rights reserved
Printed in Germany
0689 610, 06.2005

